

# M+W Instruments GmbH

## D-5100 and D-6200 hook-up diagram

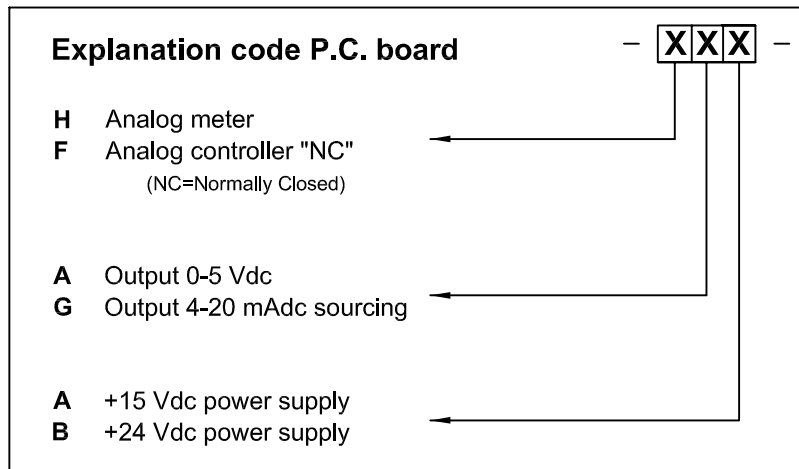

### MFM - Mass Flow Meter

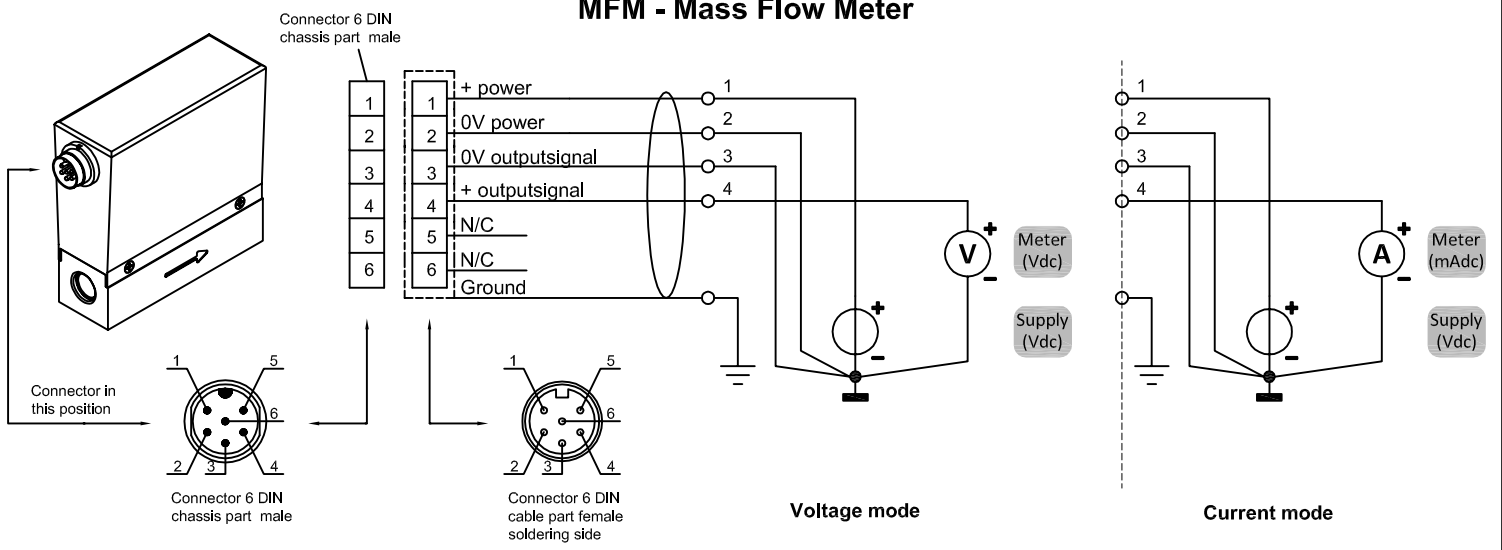

### MFC - Mass Flow Controller

